

# MPC8315E Processor Family

## Overview

The MPC8315E communications processor family enables a wide range of feature-rich applications that make the digital home experience easier, richer and safer. The cost-effective MPC8315E processor meets the requirements of several small office/home office (SOHO) applications including consumer network attached storage (NAS), digital media server, residential gateway, WLAN access point, printing, IP services and industrial control. It provides more CPU performance, additional functionality and faster interfaces while addressing important time to market, price, power consumption and real estate board requirements. The integration of Serial ATA, PCI Express® Gigabit Ethernet, high-speed USB 2.0, TDM and low-power management makes it unique in the market place. For extremely precise clock synchronization for applications such as time-sensitive telecommunications services, industrial network switches, powerline networks and test/measurement devices.

## Core Complex

The MPC8315E family incorporates a unique configuration of the e300 (603e based) core. This configuration has been designed to include dual integer units as well as a modified multiply instruction. These architectural enhancements enable more efficient operations to be executed in parallel, resulting in a significant performance improvement. The e300 core complex also includes 16 KB of L1 instruction and data caches and on-chip memory management units (MMUs).

MPC8315E Block Diagram

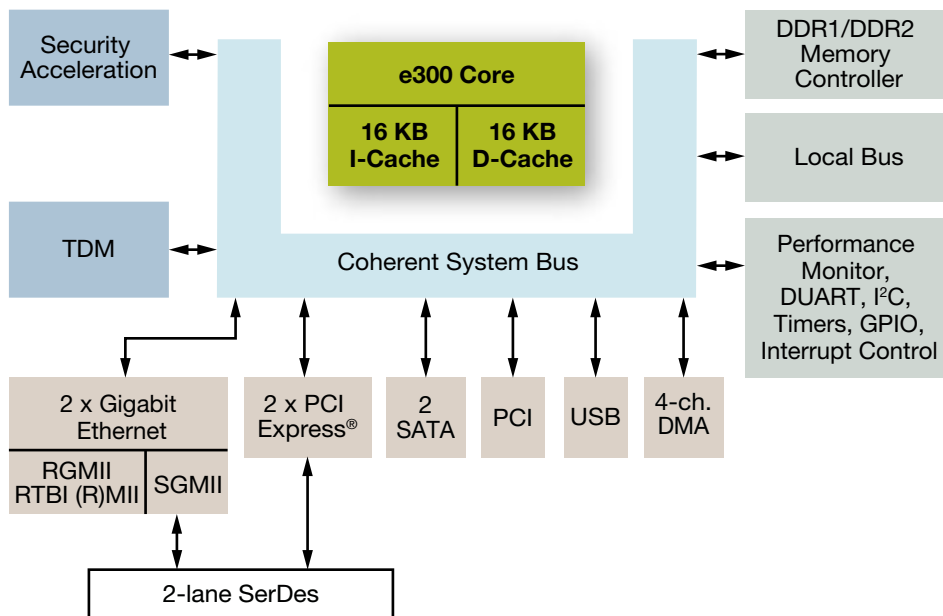

■ Core ■ Accelerators ■ I/O

## Features

- Functional Requirements
  - e300 core from 266 to 400 MHz with 16K D/I L1 cache
- I/O Description
  - 16-/32-bit DDR1/2 266 MHz
  - Enhanced local bus
  - PCI 2.3, 32-bit up to 66 MHz
  - USB 2.0 (host/device with PHY)
  - Two SATA I/II (3.0 Gbps) controllers
  - 2 x 1 PCI Express V1.0a
  - Two 10/100/1000 enhanced Ethernet MACs with PHY
    - RGMII, RTBI, RMII, MII, SGMII muxed with PCI Express
  - Multi-channel DMA controller
- Security Processing Unit
  - AES, PKEU, DES, 3DES, MDEU
  - Optimized for IPSEC and DTCP-IP
- Legacy Protocol Support
  - TDM—to connect to CODEC
- General Sampling: Now
- Production: Q2 2008
  - TEPBGA II package

	MPC8315E	MPC8314E
Core	e300	e300
CPU Speed	Up to 400 MHz	Up to 400 MHz
L1 I/D Cache	16K I Cache/16K D Cache	16K I Cache/16K D Cache
Memory Controller	16-/32-bit DDR/2 up to 266 MHz	16-/32-bit DDR/2 up to 266 MHz
Local Bus	8-bit w/NAND boot support	8-bit w/NAND boot support
PCI	32-bit up to 66 MHz (2.3)	32-bit up to 66 MHz (2.3)
PCI Express®	2 x 1	2 x 1
SATA	2 x SATA I/II (3.0 Gbps) w/PHY	-
Ethernet	Two 10/100/1000 RGMII, (R)MII, RTBI, SGMII	Two 10/100/1000 RGMII, (R)MII, RTBI, SGMII
USB	One 2.0 host or device w/PHY	One 2.0 host or device w/PHY
Security	E version only	E version only
UART	Dual	Dual
I <sup>2</sup> C	Single	Single
SPI	Yes	Yes
Interrupt Controller	Yes	Yes
Package	TEPBGA II	TEPBGA II
General Samples	Q4 2007	Q4 2007
Production	Q2 2008	Q2 2008

#### Peripheral Interfaces

The MPC8315E family also includes a 32-bit double data rate (DDR1/DDR2) memory controller, a 32-bit peripheral component interconnect (PCI) controller, a 16-bit local bus and four direct memory access (DMA) channels.

#### Hardware Security Engine

The security engine on the MPC8315E allows CPU-intensive cryptographic operations to be off-loaded from the main CPU core. The security processing accelerator provides hardware acceleration for the DES, 3DES, Advanced Encryption Standard (AES), Secure Hash Algorithm (SHA)-1 and MD-5 algorithms.

#### Cost-Effective Evaluation Board

MPC8315E-RDB (evaluation board) is available to general customers for \$499 MSRP. The kit includes Linux® 2.6 board support package (BSP) with optimized drivers to support all peripherals, and 6-month CodeWarrior® development tools evaluation license.

**Learn More:** For current information about Freescale products and documentation, please visit [www.freescale.com](http://www.freescale.com).



Freescale and the Freescale logo are trademarks or registered trademarks of Freescale Semiconductor, Inc. in the U.S. and other countries. All other product or service names are the property of their respective owners. The Power Architecture and Power.org word marks and the Power and Power.org logos and related marks are trademarks and service marks licensed by Power.org. © Freescale Semiconductor, Inc. 2008.

Document Number: MPC8315EFS  
REV 2

