

NXP Mains LED driver IC SSL2101 for dimmable LED lighting

A bright idea for dimmable LED luminaries

This small, highly integrated and highly efficient driver is the next step in SSL retrofit LED lighting. It supports the majority of available dimmers (TRIAC and transistor) and is ideal for small form-factor applications with closed casings.

Features

- ▶ High-efficiency and high power-factor for SSL applications below 15 W
- ▶ Natural dimming curve via logarithmic correction
- ▶ Supports the majority of available dimmers in the market (e.g. TRIAC, transistor)
- ▶ Fewer external components due to high integration level, ideal for small form-factor applications with closed casing
- ▶ Switched SMPS controller with buck and flyback configurations
- ▶ Thermal-enhanced & small SO16 package
- ▶ Meets safety and power-factor regulations
- ▶ Optimized valley switching with built-in, dedicated circuitry
- ▶ Built-in magnetization detection
- ▶ Built-in protection circuitry
- ▶ Supports start-up from rectified mains voltage

Applications

- ▶ SSL retrofits (e.g. GU10, E27) from 3 W to 8 W
- ▶ LED modules (e.g. LED spots, down lights) from 8 W to 15 W

The NXP Mains LED driver IC SSL2101 is a controller IC that delivers high efficiency and high power factor in SSL retrofit lamps. Supporting the majority of available dimmers (including TRIAC and transistor), it uses very few external components and is ideal for small form-factor applications that use a closed casing.

It can be used in non-isolated (buck) or isolated (flyback) configurations and is housed in a thermal enhanced package that enables a reliable and safe thermal solution. Also, for added security, it is aligned with regulations for safety and power factor.

An internal V_{CC} generator supports start-up from rectified mains voltage and there is integrated circuitry that optimizes the dimming curve. There is also a high-voltage power switch and high-voltage circuitry that supplies current to the phase-cut dimmer.

The dimming circuitry has two current sinks called bleeders. The strong bleeder is used for zero-cross dimmer resets and TRIAC latching. The weak bleeder maintains the hold current through the dimmer.



Demagnetization circuitry supports applications that have low output voltages or use a transformer with a large leakage inductance.

Several built-in protection circuits increase performance and improve system reliability. Over-temperature protection (OTP) stops IC switching when the junction temperature exceeds the thermal shutdown temperature. During thermal protection, the IC current is lowered to the start-up current. The IC resumes normal operation once the over-temperature situation goes away.

Over-current protection (OCP) limits the primary peak current from cycle to cycle, using an external source resistor to measure the current.

Short-winding protection (SWP) stops IC switching if the source voltage exceeds the threshold level, and protects against short circuits in a secondary diode.

SSL2101 block diagram

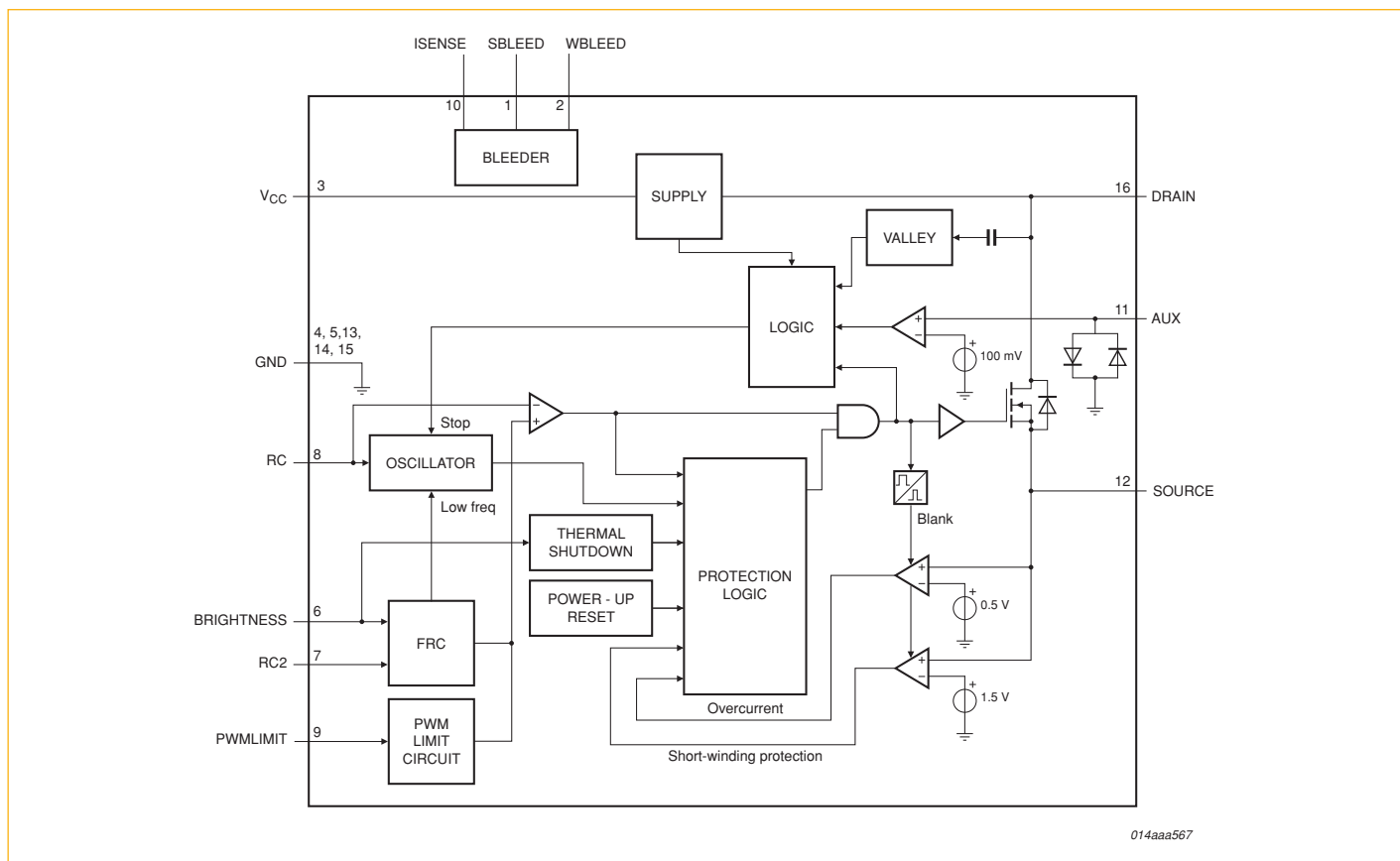

www.nxp.com

founded by

PHILIPS

© 2009 NXP B.V.

All rights reserved. Reproduction in whole or in part is prohibited without the prior written consent of the copyright owner. The information presented in this document does not form part of any quotation or contract, is believed to be accurate and reliable and may be changed without notice. No liability will be accepted by the publisher for any consequence of its use. Publication thereof does not convey nor imply any license under patent- or other industrial or intellectual property rights.

Date of release: February 2009

Document order number: 9397 750 16667

Printed in the Netherlands